

WILD HORSES

FOUR WHEEL DRIVE

Phone (209) 400-7200 Fax (209) 943-7923 www.wildhorses4x4.com

F-100 box frame bracket

#2143 Date 1/17/03 rev. 0

Parts

box bracket

Hardware

1 ea. 7/16"x 4" NC G8

2 ea. 7/16"x 1 1/2" NC G8

3 ea. 7/16 lock washers

Thanks for purchasing the Wild Horses F-100 box bracket. Years of development and improvement in this product has brought about our current one piece double gusset design. We feel this is the best F-100 bracket available.

Installation instructions:

1. Install the bracket like you see in the drawing using the original bolts that held your steering box to the frame. The bolt heads will go on the inside of the frame. Use just the lower two.
2. Weld the bracket to the frame as shown in the drawing.

Box mounting instructions:

1. The bracket is designed so that when the box is mounted it will sit at an angle on the frame. This provides extra clearance for the radiator.
2. Bolt the box up using the two lower mounting bolts and mark the frame to drill the upper mounting hole. When you drill the hole on the outside of the frame and bracket make allowance for the angle of the box.
3. For final bolting of the box to the frame and bracket start all three bolts and tighten evenly. When done the box should be at a slight angle on the frame. If necessary use one or two washers between the box and frame at the upper mounting bolt position.

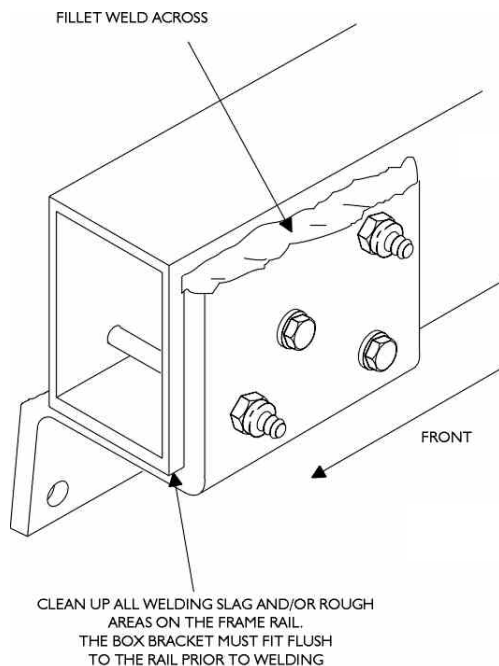

NOTE:

CLEAN THE AREA THAT THE BOX BRACKET WILL BE WELDED THOROUGHLY WITH A WIRE BRUSH, GRINDER, ETC. TO INSURE GOOD WELDS.

